

Big Blue® 500 X and 600 X

**Diesel Engine-Driven
Welder/Generator** 

Quick Specs



Heavy Industrial Applications

Heavy construction
Structural steel
Maintenance and repair rigs
Mining maintenance
Process piping
Sheet metal

Processes

Stick (SMAW)
DC TIG (GTAW)
Air carbon arc (CAC-A)

500 X

Rated: 8 mm (5/16 in.) carbons
Capable: 9.5 mm (3/8 in.) carbons

600 X

Rated: 9.5 mm (3/8 in.) carbons

Output Range

500 X CC DC stick: 55–500 A, DC/TIG: 55–500 A
600 X CC DC stick: 55–600 A, DC/TIG: 55–600 A

Generator Output Rated at 104°F (40°C)

5,500 watts peak, 4,000 watts continuous

**Accu-Rated™—Not Inflated
Generator Power**

Designed for fleet owners that demand the ultimate in reliability and performance.

Three-phase rotating field generator efficiently produces smooth DC weld output using 20 to 30 percent less fuel than a rotating armature-type DC generator.

Enclosed robust case design protects internal components from impact and allows air flow to cool and prolong the life of the engine. Also reduces sound levels.

Quick and easy maintenance with single-side access to oil level check, oil fill, oil filter, fuel filter and air cleaner.

Remote toolless oil drain allows oil to be drained without getting under the engine and reduces the chance of oil spillage.

Hot Start™ provides positive stick electrode starts making it easy to start all types of electrodes and it also works great for bead tie-ins.

HD powder coat with zinc-rich primer protects sheet metal from rust and corrosion.



Big Blue 600 X CC shown.



Heavy-duty low-speed industrial diesel engines are designed, built and proven to operate over 10,000 hours before the first basic overhaul.

Meter maintenance displays

- Fuel gauge
- Hour meter function
- Oil change interval
- High coolant temperature and low oil pressure shutdowns
- Low fuel shutdown — engine shuts down before system runs out of fuel, making restarts easy.

Arc-Drive™ makes welding easy. Automatically enhances stick welding, especially on pipe, by focusing the arc and preventing the electrode from going out.

Weatherproof Lexan® nameplate resists cracking and fading, and is color coded for ease of operation.

GFCI receptacle as required on most jobsites to protect operators from electrical hazards.

CSA, IEC and NEMA compliant for welders. Degree of protection provided by enclosure IP23.



Welder/generator is warranted by Miller for three years, parts and labor.
Engine is warranted separately by engine manufacturer.



Miller Electric Mfg. LLC
An ITW Welding Company
1635 West Spencer Street
P.O. Box 1079
Appleton, WI 54912-1079 USA

Equipment Sales US and Canada
Phone: 866-931-9730
FAX: 800-637-2315
International Phone: 920-735-4554
International FAX: 920-735-4125

MillerWelds.com



Specifications (Subject to change without notice.)



Model	Weld Mode/ Process	Weld Output Range	Weld Output Rated at 40°C (104°F)	Max. Open-Circuit Voltage	Generator Output Rated at 40°C (104°F)	Dimensions***	Weight (without fuel)****
Big Blue 500 X CC	CC/DC (Stick/TIG)	55–500 A	Deutz and Perkins 400 A at 36 V, 100% duty cycle* 450 A at 38 V, 60% duty cycle 500 A at 30 V, 40% duty cycle	92	5,500 watts peak 4,000 watts continuous 1-phase, 34/17 A, 120/240 V, 50/60 Hz while welding	H: 1,092 mm (43 in.) W: 724 mm (28.5 in.) D: 1,654 mm (65.125 in.)	Perkins 404D.22: 701 kg (1,545 lb.) Deutz D2011L03i: 751 kg (1,655 lb.)
Big Blue 600 X CC	CC/DC (Stick/TIG)	55–600 A	Deutz 500 A at 40 V, 100% duty cycle* 550 A at 34 V, 60% duty cycle 600 A at 30 V, 40% duty cycle				Deutz D2011L04i: 769 kg (1,695 lb.)

*Meets NEMA and IEC output ratings. **Perkins powered model with lowered ratings to meet CE sound ratings.

Additional 178 mm (7 in.) to top of exhaust. *Additional 86 kg (190 lb.) when fuel tank is full.

Control Panel

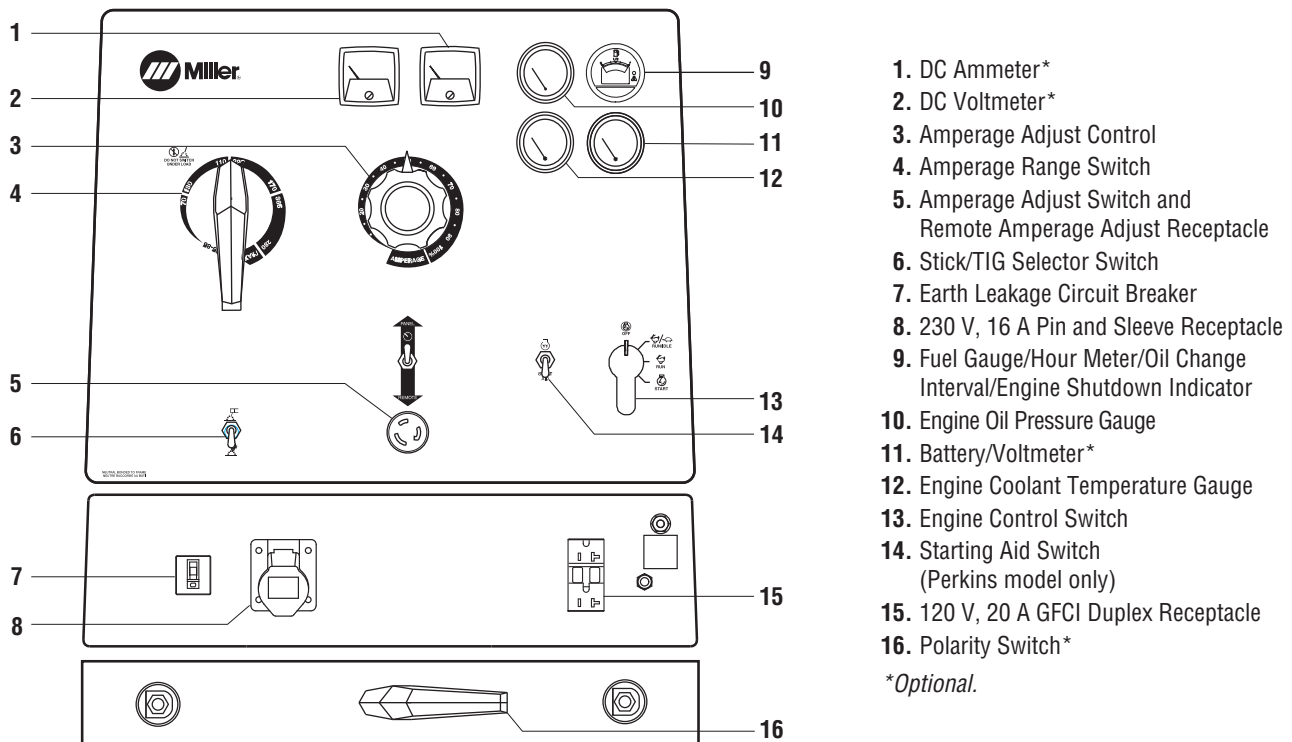

1. DC Ammeter*
2. DC Voltmeter*
3. Amperage Adjust Control
4. Amperage Range Switch
5. Amperage Adjust Switch and Remote Amperage Adjust Receptacle
6. Stick/TIG Selector Switch
7. Earth Leakage Circuit Breaker
8. 230 V, 16 A Pin and Sleeve Receptacle
9. Fuel Gauge/Hour Meter/Oil Change Interval/Engine Shutdown Indicator
10. Engine Oil Pressure Gauge
11. Battery/Voltmeter*
12. Engine Coolant Temperature Gauge
13. Engine Control Switch
14. Starting Aid Switch (Perkins model only)
15. 120 V, 20 A GFCI Duplex Receptacle
16. Polarity Switch*

*Optional.

Additional Features

Proven, rugged rheostat control technology that has been in Miller engine drives for over 60 years. Contains no printed control boards.

A **stick/TIG switch** optimizes open-circuit voltage for stick welding and allows the open-circuit voltage to be lowered for scratch start TIG welding.

Provisions are provided to plug a **RHC3GD34A remote control** that will allow precise adjustment of amperage without walking back to the machine.

Performance Data

500 X CC
Volt/Amp Curves – Stick Mode

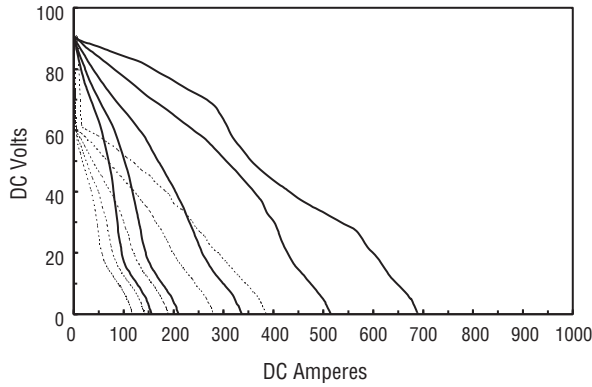

600 X CC
Volt/Amp Curves – Stick Mode

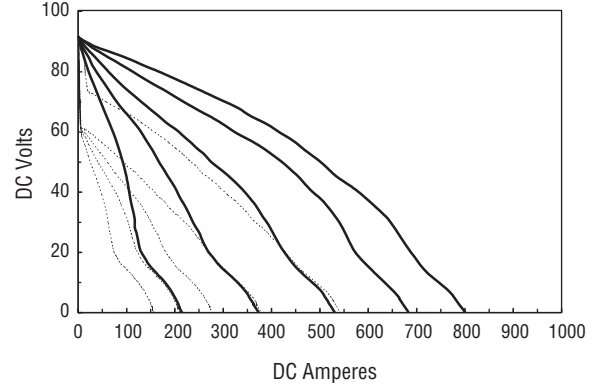

Fuel Consumption Curve

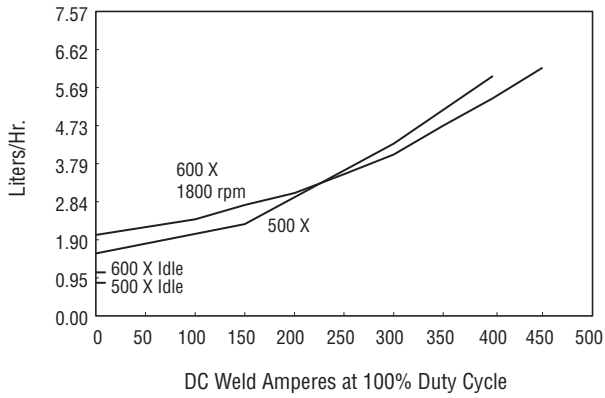

Duty Cycle Curve

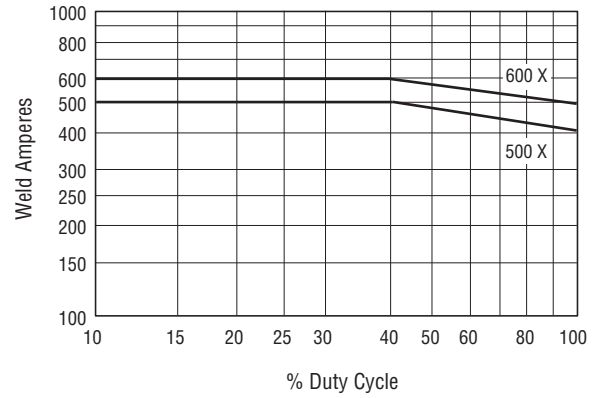

Generator Power Curve

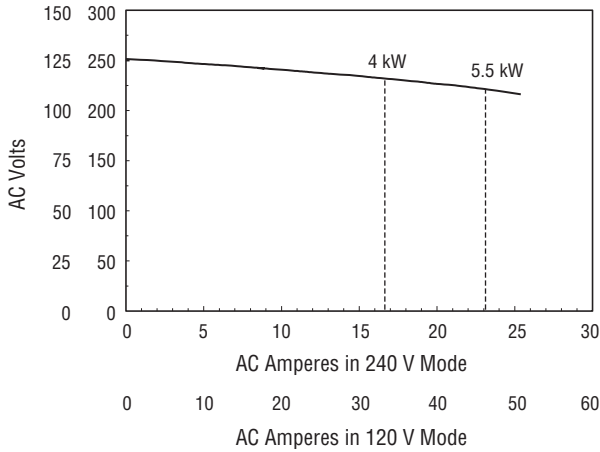

Engine Specifications (Subject to change without notice.)

Model	Engine Brand	Features	HP	Type	Engine Speeds	Capacities	Automatic Engine Shutdowns
Big Blue 500 X	Perkins 404D.22	EPA Tier 4i compliant, indirect-injected, liquid-cooled engine with rated sound levels of 73.2 dB at 7 m (97 Lwa). Right-side service access with intervals of 500 hours for oil and filters.	32.6	Four-cylinder, industrial, liquid-cooled diesel	Weld: 1,850 rpm	Fuel: 95 L (25 gal.) Oil: 8.5 L (9 qt.) Coolant: 8.5 L (9 qt.)	Low oil pressure, high coolant temperature, low fuel level
	Deutz D2011L03i	EPA Tier 4i compliant, direct-injected, air/oil-cooled engine with full load sound levels of 76.8 dB at 7 m (101.7 Lwa). Right-side service access with intervals of 1,000 hours for oil and filters. Approved underground operation with the purchase of a MSHA (30 CFR part 7) certificate.	32.0	Three-cylinder, industrial, air/oil-cooled diesel	Weld: 1,850 rpm	Fuel: 95 L (25 gal.) Oil: 5.9 L (6.2 qt.) Coolant: Integrated oil	Low oil pressure, high coolant temperature, low fuel level
Big Blue 600 X	Deutz D2011L04i	EPA Tier 4i compliant, direct-injected, air/oil-cooled engine with full load sound levels of 76 dB at 7 m (101 Lwa). Right-side service access with intervals of 1,000 hours for oil and filters.	48.6	Four-cylinder, industrial, air/oil-cooled diesel	Weld: 1,850 rpm	Fuel: 95 L (25 gal.) Oil: 8.5 L (9 qt.) Coolant: Integrated oil	Low oil pressure, high coolant temperature, low fuel level

Genuine Miller® Options

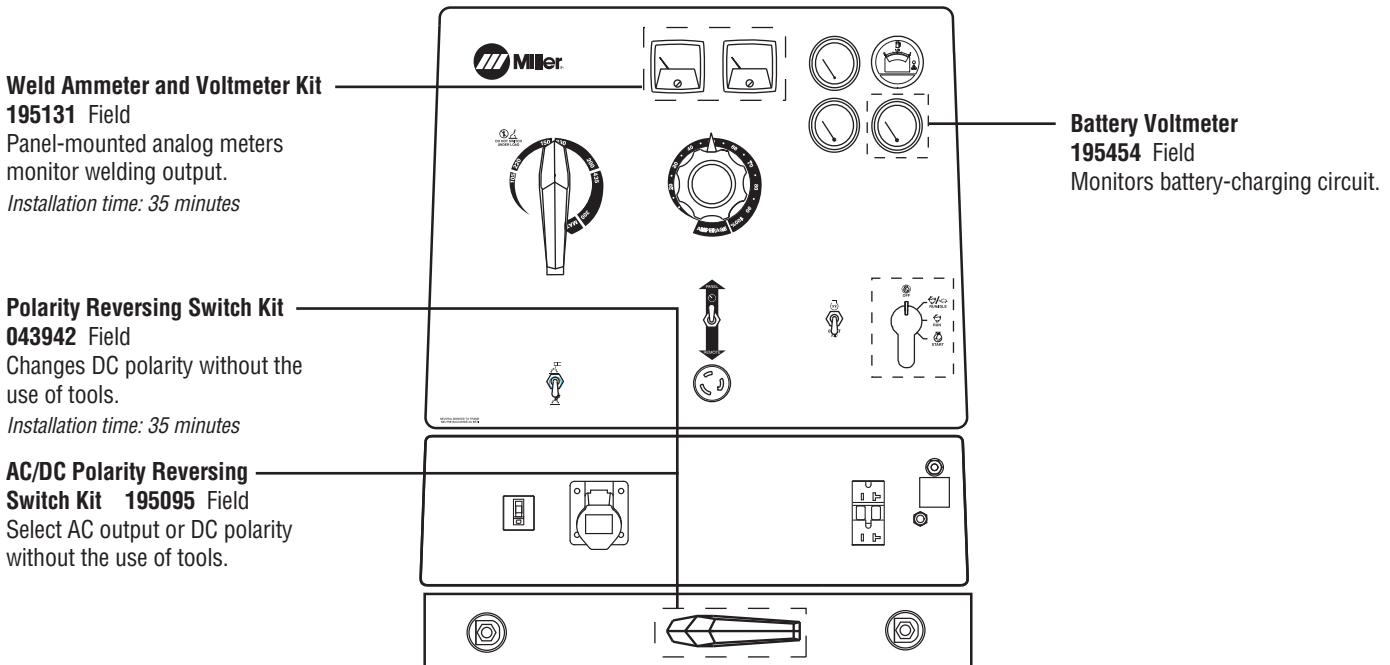

Genuine Miller® Accessories



International Plug
255416 Field
1-phase, 240 V, 16 A plug

Engine Filter Kits

246988 Field. For Deutz D2011

246985 Field. For Perkins 404

Includes all filters required for proper engine maintenance. Oil filter, primary and secondary fuel filter, and primary air filter.



Spark Arrestor Kit

195012 Field
Prevents particles from leaving the muffler that could

potentially start a fire. Mandatory when operating on California grasslands, brush, or forest-covered land, and in all national forests. For other areas, check your state and local laws. Meets U.S. Forest Service standard 5100-1B.



FA-1D Lockable Flame Arrestor

Fuel Cap 043947 Field

Fuel cap can be padlocked to prevent vandalism. A built-in flame arrestor prevents flames or sparks from entering the fuel tank.



Vandalism Lockout Kit

195118 Field
Lockable hinged steel panels cover and protect name plate gauges and ignition switch (padlock included). Also includes engine compartment door lock and key.



Cable Holder

043946 Field
Saddle-bag-style cable holder. Convenient wrap-around storage of coiled cable for transportation. Stores 30.5 m of 2/0 cable on each side.

*Note: For best results do not weld when cable is coiled!
Protective cover cannot be used with cable holder.*



Protective Cover 194683

Field
Blue water-resistant canvas cover resists stains and mildew, and protects the finish of your welder.

Note: Protective cover cannot be used with cable holder.

Stick (SMAW) Welding



Weld Leads

2/0 Stick Cable Set, 15 m (50 ft.)
173851

Consists of 15 m (50 ft.) 2/0 electrode cable with holder, and 15 m (50 ft.) work cable with clamp. 350 A, 100% duty cycle.

2/0 Stick Cable Set, 30.5/15 m (100/50 ft.)
043952

Consists of 30.5 m (100 ft.) 2/0 electrode cable with holder, and 15 m (50 ft.) work cable with clamp. 300 A, 100% duty cycle.

AC TIG (GTAW) Welding



Dynasty® 210 Series

For portable AC/DC TIG. See literature AD/4.81.

Plasma Cutting



Spectrum® 375 X-TREME™ 907529

Comes complete with protective X-CASE™ (not shown). See literature PC/9.2.

Remote Control



RHC-3GD34A Remote Hand Control 041122

Allows for precise adjustment of amperage. Includes 6 m (20 ft.) cord.

Trailers and Hitches (Note: Trailers are shipped unassembled.)



4 West Four-Wheel Steerable Off-Road Trailer 042801

A heavy-duty 1,166 kg (2,570 lb.) capacity trailer designed for use in mines, quarries, and other rough terrain. Has narrow 6.7 m (22 ft.) turning radius. Includes 76 mm (3 in.) lunette eye, universal hitch and safety chains.



HWY-225 Trailer 301338

A 1,225 kg (2,700 lb.) capacity highway trailer with welded steel tubing frame, heavy-duty axle with roller bearing hubs and leaf-spring suspension. Includes jack stand, fenders, lights, and dual hitch with 50 mm (2 in.) ball hitch and 76 mm (3 in.) lunette eye.

Cable Tree 043826

Provides an area to conveniently wrap weld cables and extension cords.



2-In-1 Document/Fire Extinguisher Holder 301236

For use with HWY-225.

Stores documents and holds a 5-pound fire extinguisher.

Note: Holder shown mounted on trailer. Fire extinguisher not included.

Trailer Specifications (Subject to change without notice.)

Model	Gross Axle Weight Rating	Gross Vehicle Weight Rating	Net Payload	Height of Bed	Road Clearance	Track (Center to center of tires)	Standard Tires (Standard rating or P-size rating)	Dimensions	Net Weight
4 West	907 kg/axle (2,000 lb./axle)	1,361 kg (3,000 lb.)	1,157 kg (2,550 lb.)	540 mm (21.25 in.)	203 mm (8 in.)	1,403 mm (55.25 in.)	B78-13	Length: 2,311 mm (91 in.)* Width: 1,556 mm (61.25 in.)	195 kg (430 lb.)
HWY-225	1,588 kg (3,500 lb.)	1,360 kg (2,999 lb.)	1,225 kg (2,700 lb.)	483 mm (19 in.)	191 mm (7.5 in.)	1,270 mm (50 in.)	ST175/80R-13 Load Range D	Length: 2,680 mm (105.5 in.) Width: 1,435 mm (56.5 in.)**	127 kg (280 lb.)

*Does not include tongue. **Width at outside of fenders.

Mounting Specifications

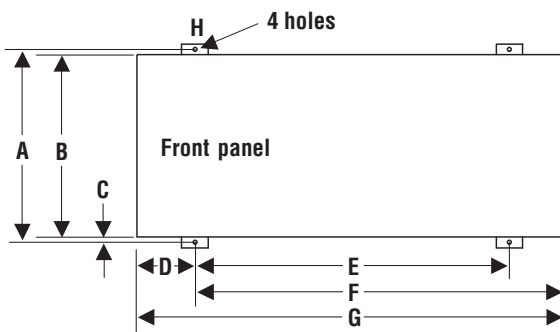

A. 757 mm (29.812 in.)

B. 699 mm (27.5 in.)

C. 25 mm (1 in.)

D. 244 mm (9.625 in.)*

E. 1,181 mm (46.5 in.)*

F. 1,422 mm (56 in.)*

G. 1,654 mm (65.125 in.)

H. 14 mm (.562 in.) diameter

*With mounting brackets in center position. Dimensions vary with location of mounting brackets.

Height: 1,270 mm (50 in.)
(to top of exhaust)

Width: 724 mm (28.5 in.)
(mounting brackets turned in)
781 mm (30.75 in.)
(mounting brackets turned out)

Depth: 1,654 mm (65.125 in.)

Typical Installations

Electrode Hot



Stick (SMAW) Basic Equipment



Scratch Start TIG (GTAW) Basic Equipment

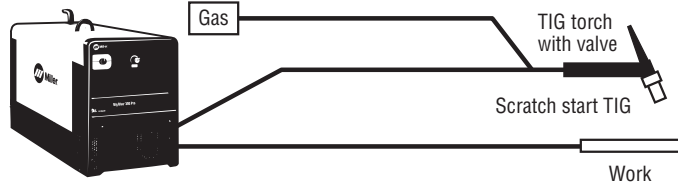

Remote On/Off Required



Stick (SMAW) Basic Equipment
RHC-3GD34A 041122

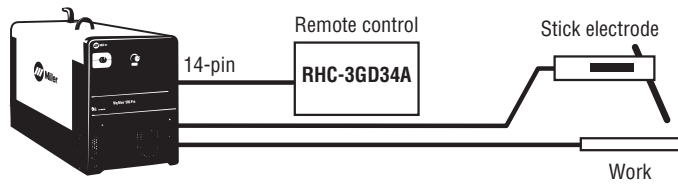

Plasma Basic Equipment
Spectrum® 375 X-TREME™ 907529

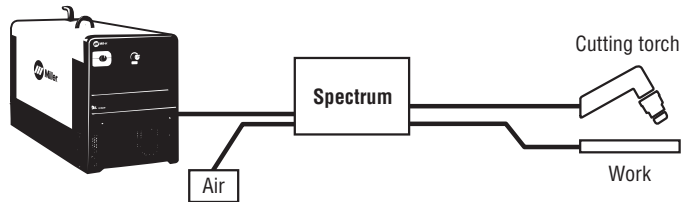

Ordering Information

Equipment and Factory Options	Stock No.	Description	Qty.	Price
Big Blue® 500 X CC	907185	Deutz D2011L03i with engine gauges		
Big Blue® 600 X CC	907193	Deutz D2011L04i with engine gauges		
Field Accessories				
Weld Ammeter and Voltmeter Kit	195131	For all models. Analog welding meters		
Polarity Reversing Switch Kit	043942	For all models. DC polarity switch		
	195095	For all models. AC/DC polarity switch		
Battery Voltmeter	195454	For all models. Analog		
International Plug	255416	1-phase, 240 V, 16 A		
Engine Filter Kit	246988	Deutz D2011. Includes air, oil and fuel filters		
	246985	Perkins 404. Includes air, oil and fuel filters		
Spark Arrestor Muffler Kit	19 012	For all models. Horizontal externally mounted		
Lockable Flame Arrestor Fuel Cap	043947	For all models. Padlock not included		
Vandalism Lockout Kit	195118	For all models. Lockable front control panel and engine compartment		
Cable Holder	043946	For all models. Stores up to 61 m (200 ft.) of 2/0 weld cable		
Protective Cover	194683	For all models. Will not fit over machine with cable holder attached		
Stick Welding				
Weld Leads	173851	2/0, 350 A, 100% duty cycle, 15 m (50 ft.) stinger, 15 m (50 ft.) work clamp		
	043952	2/0, 300 A, 100% duty cycle, 30.5 m (100 ft.) stinger, 15 m (50 ft.) work clamp		
AC TIG Welding				
Dynasty® 210 Series		See literature AD/4.81		
Plasma Cutting				
Spectrum® 375 X-TREME™	907529	Includes X-CASE™. See literature PC/9.2		
Remote Control				
RHC-3GD34A Hand Control	041122			
Trailers and Hitches				
4 West Four-Wheel Steerable Trailer	042801	Trailer with lunette eye, universal hitch and safety chains. For off-road use		
HWY-225 Trailer	301338	Trailer with lights, fenders and dual hitch. For highway use		
Cable Tree	043826	Trailer-mounted cable holder for HWY-225		
2-In-1 Document/Fire Extinguisher Holder	301236	Stores documents and holds a 5-pound fire extinguisher for HWY-225		

Date:

Total Quoted Price:

Distributed by:

