

# Responder 140

## Mobile Foam Monitor Unit

- Self-contained mobile foam unit
- Rapid deployment of foam extinguishing agent
- Improved handling and mobility
- Low maintenance



With rapid deployment at the forefront of its design The Angus Hi-Combat Responder 140 is a fully self-contained mobile foam monitor unit, which has been specifically developed for a fast response by a single person to fight fires.

The unit has excellent handling and mobility as a result of the low centre of gravity and features solid rubber tyres to enable movement over difficult terrain. The usability of the Angus Responder 140 is further enhanced by the addition of screw shaft prop outriggers which provide stability when the monitor is in action.

To operate simply connect the Angus Duraline fire hose which is supplied with the unit to a suitable water supply, open the valve and allow the water to flow to the monitor. Foam is induced automatically by opening the foam valve. The unit can be used for cooling-water only, or fire fighting with foam.

The standard unit comprises of a 140 litre foam concentrate tank, and Angus 605 bronze industrial monitor and an Angus Hi-Combat 883 bronze nozzle. Also included is a 15m length of Dutch coiled 45mm diameter Duraline fire hose fitted with 2.5" instantaneous couplings (other connections available to special order). Two ball valves are also fitted, one on the water inlet and one on the foam induction line.

The rugged flow-efficient Angus 605 monitor is highly versatile and requires minimal maintenance; it is designed with a stainless steel lever for durability and easy control.

The Hi-Combat nozzle is adjustable from straight stream to fog. This combination gives the fire fighter the ability to fight a significant sized fire from a safe distance and once set up in position the monitor can be locked and left in position.

The Angus Hi-Combat Responder 140 is ideal for the protection of oil storage and loading terminals, small airfields, industrial sites and similar high risk areas.

Developed for on hand fast response with minimal manpower requirements, this highly versatile unit is suitable for use with any Angus film forming foam (FFF) and is particularly effective when used with Angus Tridol Ultra 3% AFFF, as well as Alcolseal and Petroseal film forming fluoro-protein foams at 3% non-aspirating.

All component parts and materials have been selected to minimise maintenance requirements.

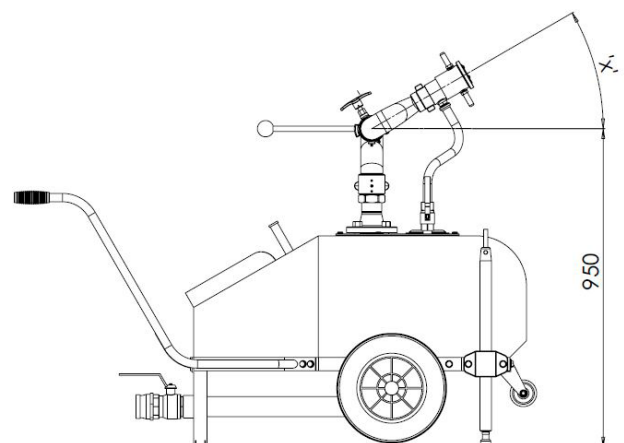
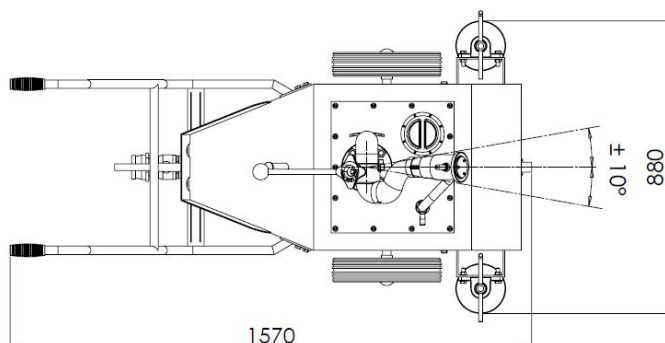

# Responder 140

## Mobile Foam Monitor Unit

Performance	
Recommended Pressure Range	Min 3 bar g; Max 10 bar g
Nozzle 'K' Factor	323
Optimum Operating Pressure	7 bar g
Max Throw (@ 10 bar g)	40m
Angle of Monitor to Achieve Max Throw	30°
Max Height (@ 10 bar g)	10m
Angle of Monitor to Achieve Max Height	75°

### Operating Time

Using Angus AFFF (Tridol) or FFFP (Petroseal & Alco seal) concentrates and the 883-BC self-inducing nozzle at 3% induction rates, the Responder 140 provides a typical operating time of 5.5 minutes, when operating at 7 bar g with a flow rate of 850 lpm.

Construction	
Foam Tank	Thermoplastic coated steel
Tank Capacity	140 litres
Chassis	Thermoplastic coated steel
Tyres	Solid rubber
Monitor	Style 605 Bronze
Nozzle	883-BC self inducing Bronze

Typical Packing Specification	
Container	One Case (Plywood)
Approx case dimensions	1650mm x 950mm x 1200mm
Dimensions of Responder 140	1570mm x 880mm x 1100mm (min height)
Approx Responder 140 weight (empty)	120kg

### Ordering Information

#### Part number AT111100

Angus Responder 140-litre mobile foam tank with Style 605 Bronze monitor & Style 883-BC-SI nozzle.

Max flow 850LPM.

Supplied with: -

2 x screw down jacks

2 x solid wheels

1 x 15m x 45mm Duraline fire hose with 2½-inch British instantaneous couplings in light alloy

#### Part number XA6024Y

Cover – Yellow PVC

Standard unit is fitted with 2½-inch British instantaneous connections in light alloy.

Other connections and materials available on request.

#### INTERNATIONAL SALES

##### Angus Fire Ltd

Angus House, Haddenham Business Park,  
Pegasus Way, Haddenham, Aylesbury, HP17 8LB, UK  
Tel: +44 (0)1844 293600 • Fax: +44 (0)1844 293664

#### UK SALES

##### Angus Fire Ltd

Station Road, Bentham, Lancaster, LA2 7NA, UK  
Tel: +44 (0)1524 264000 • Fax: +44 (0)1524 264180

Angus Fire operates a continuous programme of product development. The right is therefore reserved to modify any specification without prior notice and Angus Fire should be contacted to ensure that the current issues of all technical data sheets are used.

© Angus Fire  
6787/2 05.16